



## Electrical Characteristics

(Unless otherwise specified condition shall be  $V_{IN}=3.5V, V_O=2.48V (R1=R2=10k\Omega), I_O=30mA, V_C=1.8V, T_a=25^\circ C$ )

Parameter	Symbol	Conditions	MIN.	TYP.	MAX.	Unit
Input voltage	$V_{IN}$	—	2.5	—	15.0	V
Output voltage	$V_O$	—	$V_{ref}$	—	9.0	V
Reference voltage	$V_{ref}$	—	1.215	1.24	1.265	V
Load regulation	$Reg_L$	$I_O=5$ to $500mA$	—	35	100	mV
Line regulation	$Reg_L$	$V_{IN}=3.5V$ to $8.5V$	—	6	20	mV
Temperature coefficient of Reference voltage	$TcV_{ref}$	$I_O=10mA, T_j=0$ to $100^\circ C$	—	$\pm 1.0$	—	%
Ripple rejection	RR	Refer to Fig.2	—	50	—	dB
Output noise voltage	$V_{no(rms)}$	$10Hz < f < 100kHz$	—	180	—	$\mu V$
Dropout voltage	$V_{I-O}$	$V_{IN}=3V, I_O=300mA$	—	—	0.7	V
*4 On-state voltage for control	$V_{C(ON)}$	—	1.8	—	—	V
On-state current for control	$I_{C(ON)}$	$V_C=1.8V$	—	5	30	$\mu A$
Off-voltage for control	$V_{C(OFF)}$	—	—	—	0.4	V
Quiescent current	$I_q$	$I_O=0mA$	—	400	700	$\mu A$
Output off-state consumption current	$I_{qs}$	$V_C=0.2V$	—	—	1	$\mu A$

\*4 In case that the control terminal (③ pin) is non-connection, output voltage should be OFF state.

Fig.1 Standard measuring circuit of Regulator portion

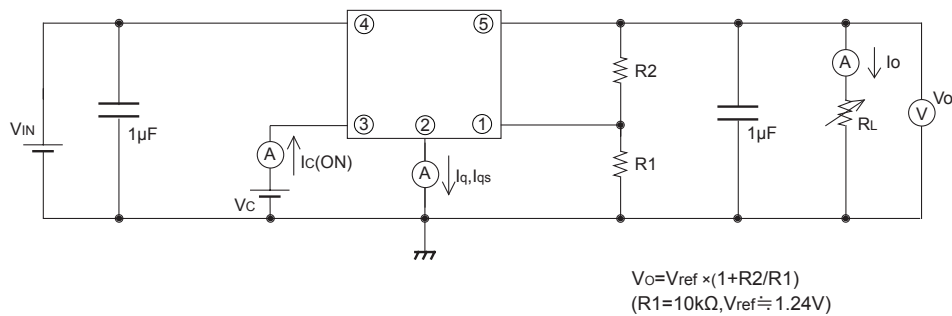

Fig.2 Standard measuring circuit of critical rate of ripple rejection

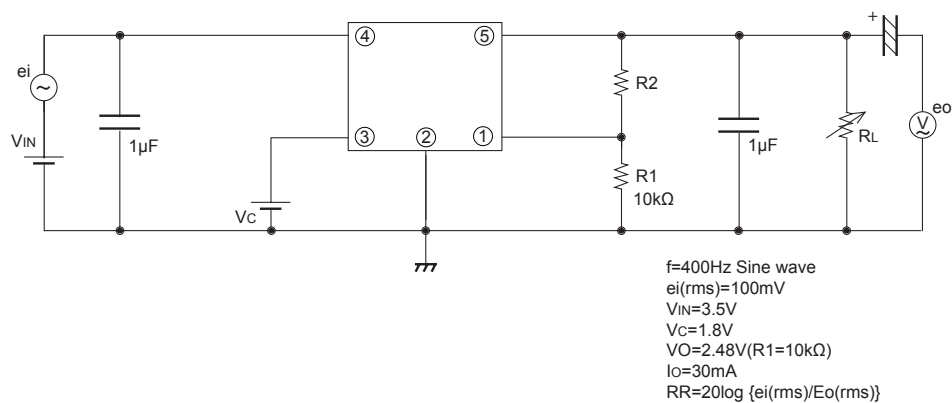
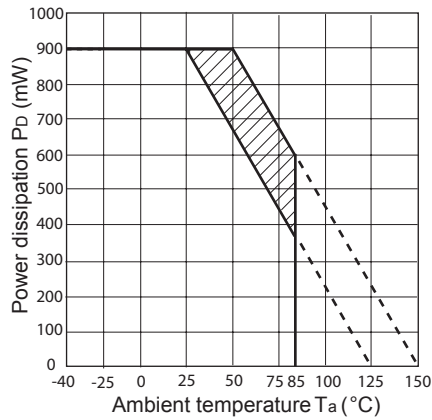
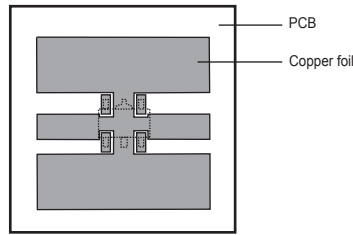

Fig.3 Power Dissipation vs. Ambient Temperature



Mounting PCB



Material : Glass-cloth epoxy resin  
 PCB Size : 20mm × 20mm × 1.0mm  
 Copper foil area : 180mm<sup>2</sup>  
 Thickness of copper : 35μm

Note) Oblique line portion: Overheat protection may operate in this area.

Fig.4 Overcurrent Protection Characteristics

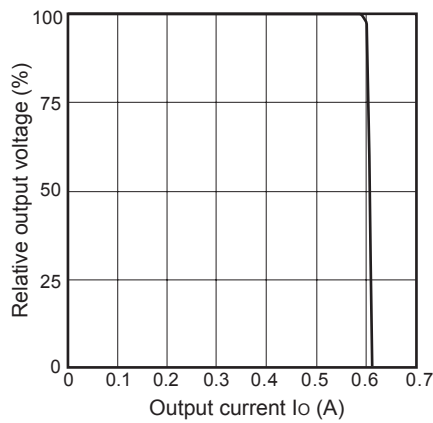

Fig.5 Output Voltage vs. Input Voltage (Typical Value)

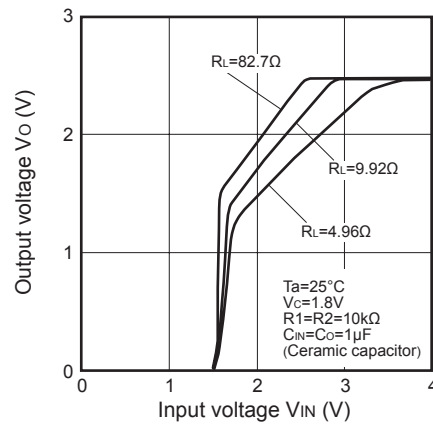

Fig.6 Circuit Operating Current vs. Input Voltage (Typical Value)

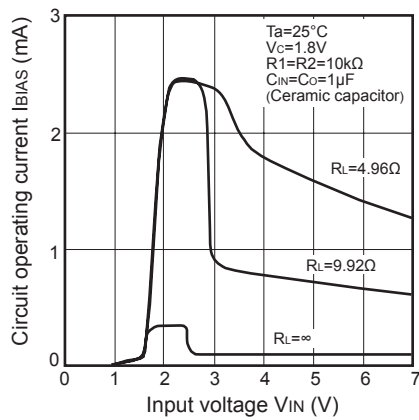

Fig.7 Quiescent Current vs. Junction Temperature (Typical Value)

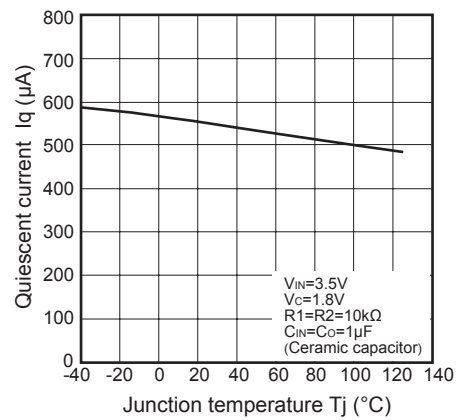

Fig.8 Dropout Voltage vs. Junction Temperature (Typical Value)

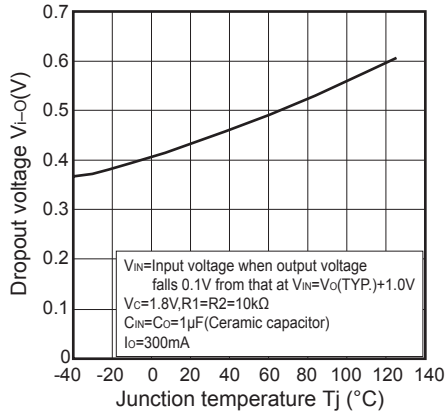

Fig.9 Output Voltage Deviation vs. Junction Temperature (Typical Value)

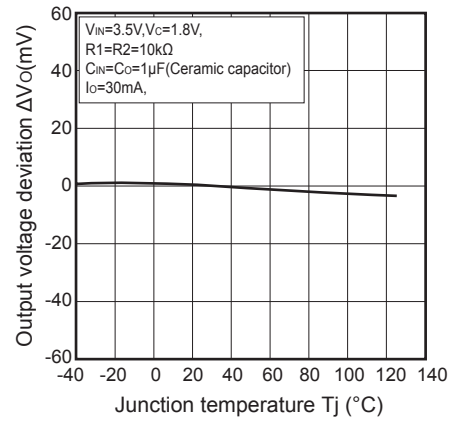

Fig.10 Dropout Voltage vs. Output Current (Typical Value)

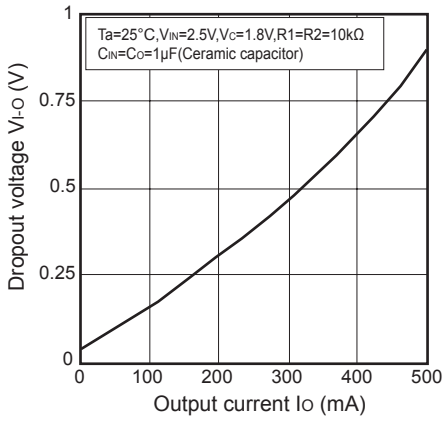

Fig.11 Ripple Rejection vs. Input Ripple Frequency (Typical Value)

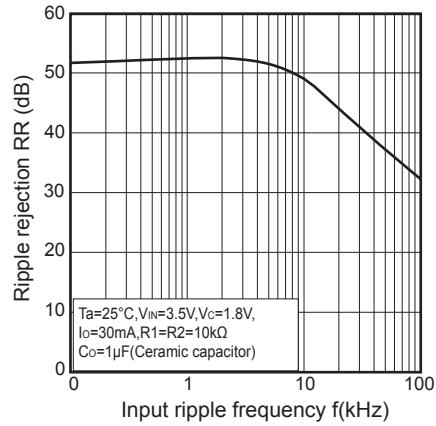
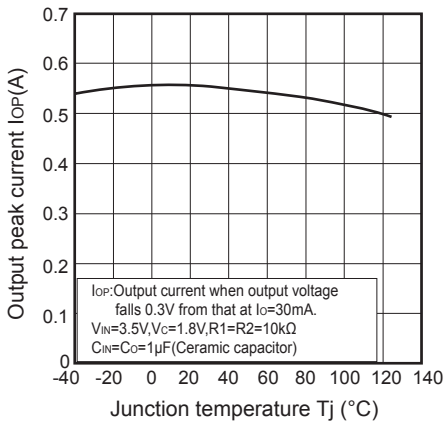

Fig.12 Output Peak Current vs. Junction Temperature (Typical Value)



■ Example of application

