

© 1967 BY AMP INCORPORATED. ALL RIGHTS RESERVED. AMP PRODUCTS COVERED BY PATENTS AND/OR PATENTS PENDING.

REVISIONS				
ZONE	LTR	DESCRIPTION	DATE	APPROVED
	B	REDRAWN & REV. P-6077 SK	7-30-69	FCY
	C	REVISED PC-5579 WM	10-8-70	<i>Jme</i>
	D	REV. & ADDED TAPE NO. PC-5578 WM	7-6-71	FCY
	E	REVISED PC-5578 TL	2-23-77	LD
	F	REV / 0610-0099-98	2-5-99	ME / MS
	F1	REV PER ECR 05-013140	10/20/05	DR/TM

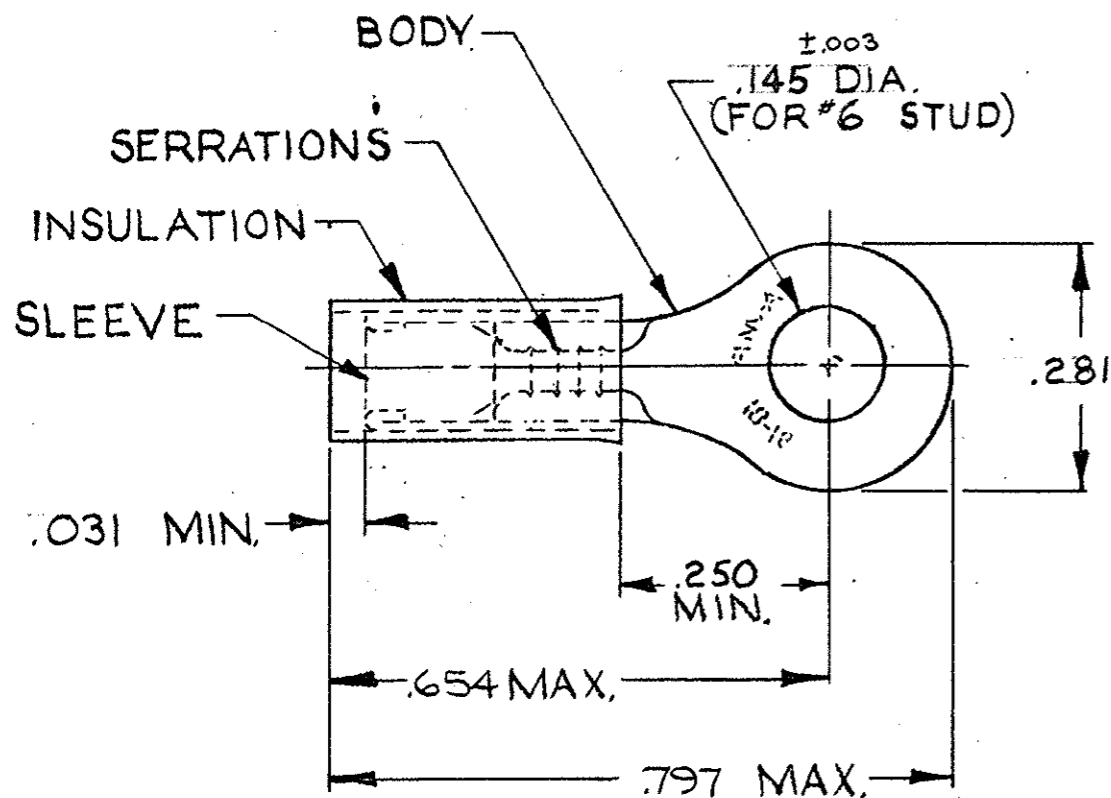

FOR .055 TO .135 WIRE INSULATION DIA.
TONGUE MATERIAL THK. = .031 ±.002

1	50835 ON TAPE	50835-1	BODY: COPPER (ASTM B 152) NICKEL PLATE (QQ-N-290) .0003 AVG. EXT. THK.
1	WIRE TERMINAL	50835	SLEEVE: COPPER (ASTM B 152) NICKEL PL (QQ-N-290). 00003 AVG. EXT. THK. INSULATION: TEFLON (ASTM-D329.51) COLOR: ORANGE
QTY	DESCRIPTION	PART NO.	MATERIAL & FINISH
UNLESS OTHERWISE SPECIFIED DIMENSIONS ARE IN INCHES TOLERANCES ON: DECIMALS ±.008 ANGLES ± 5°		CONTRACT NO. <u>H</u>	AMP AMP INCORPORATED HARRISBURG, PENNSYLVANIA
MATERIAL SEE TABLE		DR. <i>Steve Kautz</i> 7-24-69 CHK. <i>R. Young</i> 7-30-69 APPD. <i>Swabell</i> 8-6-69 REL. <i>AM Ensminger</i> 8-6-69 DSGN APPD. OTHER APPD.	
		SIZE B	CODE IDENT NO. 00779
		SCALE NTS.	NUMBER 50835
			SHEET 10F1