

**PROPER USE GUIDELINES**

Cumulative Trauma Disorders can result from the prolonged use of manually powered hand tools. Hand tools are intended for occasional use and low volume applications. A wide selection of powered application equipment for extended-use, production operations is available.

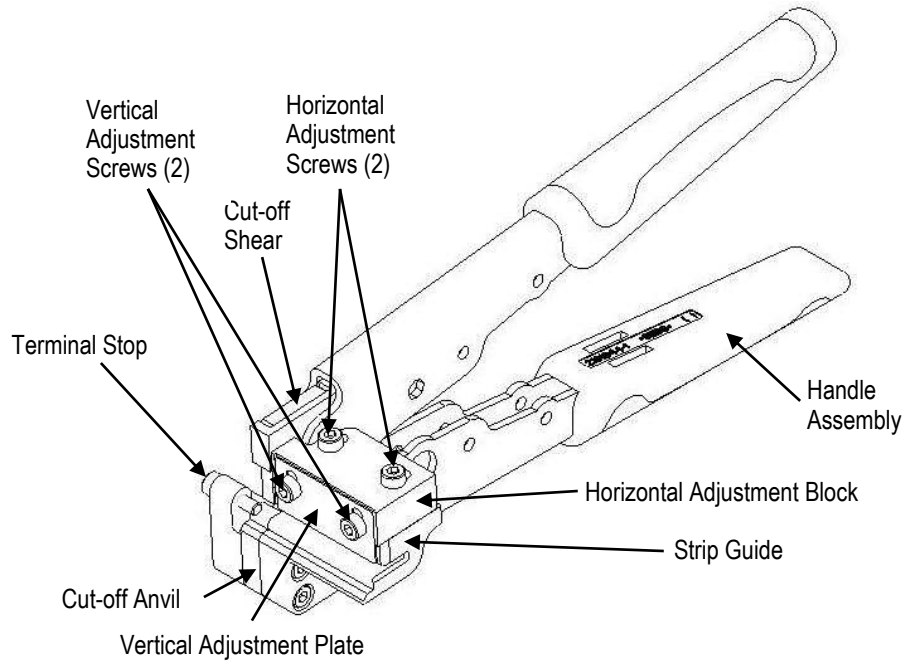

Figure 1

**1. INTRODUCTION**

The Light Duty Side Feed Terminal Cutter (PN 2305570-1) is designed to loose piece (cut) side-feed, front-carrier terminals from the carrier strip.

**2. DESCRIPTION**

- ◆ The tool is comprised of a Handle Assembly, Cut-off Anvil, Cut-off Shear, Strip Guide, Horizontal Adjustment Block, Vertical Adjustment Plate, and Terminal Stop (reference Figure 1).
- ◆ The tool adjustment specifications are presented in Figure 2.



**NOTE**

*Dimensions in this Instruction Sheet are in inches [with millimeters in brackets]. Figures are not drawn to scale, but only for reference.*

<b>Tab Width</b>	<b>Barrel Width</b>	<b>Barrel Height</b>		<b>Stock Thickness</b>
(Max)	(Max)	(Min)	(Max)	(Max)
.130 [3.30]	.175 [4.45]	.050 [1.30]	.325 [8.30]	.024 [0.61]

Figure 2

### 3. TERMINAL DESCRIPTION



**NOTE**

*This tool is designed specifically to loose piece side-feed front-carrier terminals. Tool is not designed to loose piece end-feed, center-carrier or dual-carrier terminals.*

#### 3.1. Side-Feed Front-Carrier Terminals

Terminal consisting of a contact body, crimp barrels, tab and single-carrier strip located adjacent to the crimp barrels.

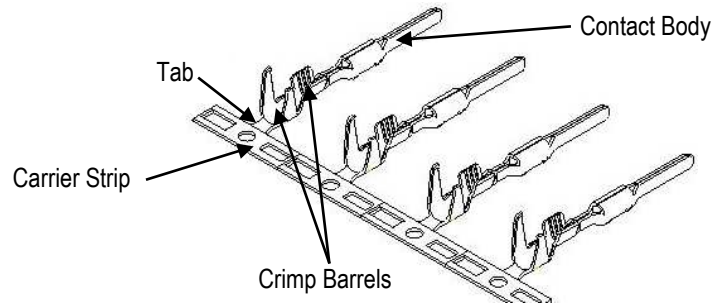

Figure 3

#### 3.2. End-Feed Terminals

Terminal consisting of a contact body, crimp barrels and tab. The tab is located between the contact body and crimp barrels of the next terminal in sequence.

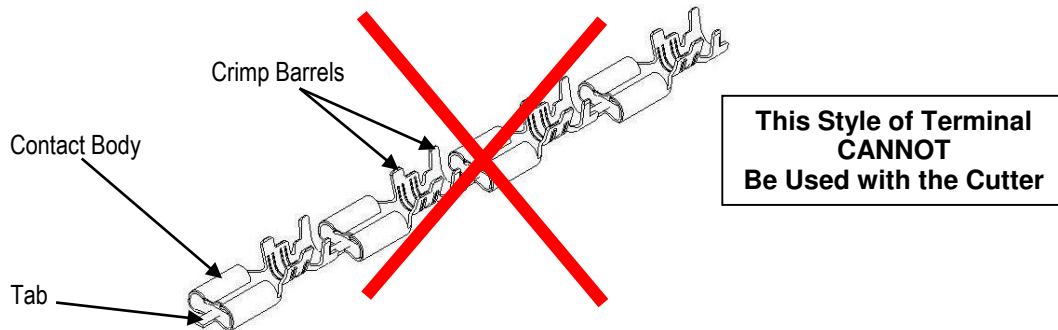

Figure 4

#### 3.3. Center-Carrier Terminals

Terminal consisting of a contact body, crimp barrels (or other style termination feature) and tab. The tab is located between the contact bodies of the terminals.

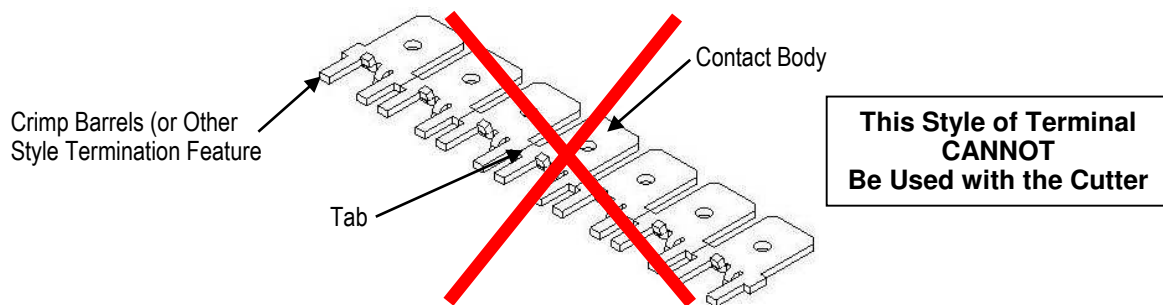

Figure 5

### 3.4. Dual-Carrier Terminals

Terminal consisting of a contact body, crimp barrels, a tab and carrier strip adjacent to the crimp barrels of the contact, and, a tab and carrier strip adjacent to the contact body portion of the contact.

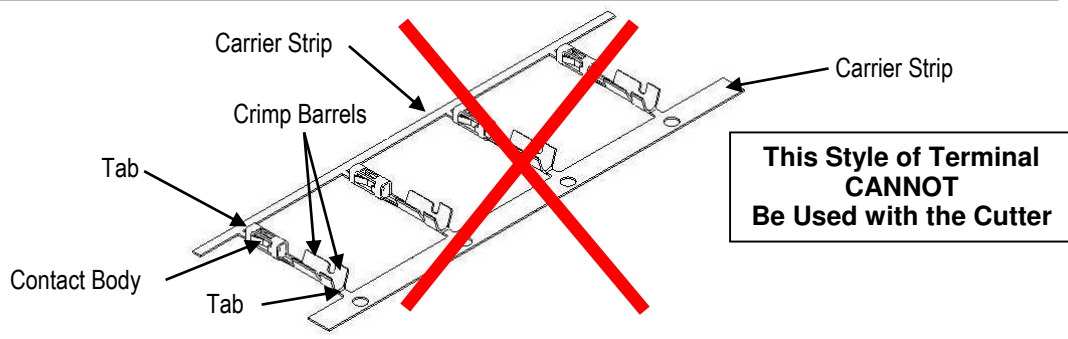

Figure 6

### 4. ADJUSTMENT PROCEDURE [FIGURE 7]



**NOTE**

The adjustment procedure is performed most easily with a small strip of terminals - approximately 4 to 5.

1. Loosen the Vertical and Horizontal Adjustment Screws just enough to allow the Vertical Adjustment Plate and Horizontal Adjustment Block to move.
2. Move the Vertical Adjustment Plate and Horizontal Adjustment Block so the terminal strip can be inserted into the Strip Guide; positioning the contact barrel against the Strip Guide surface indicated (see Figure 7).
3. Lower the Vertical Adjustment Plate into the transition area between the Insulation Barrel and the Wire Barrel of the terminal.



**NOTE**

Some terminals do not have an Insulation Barrel – in that case, use the transition area between the Wire Barrel and the Contact Body to set up the tool (see Figure 7; Contact Details).

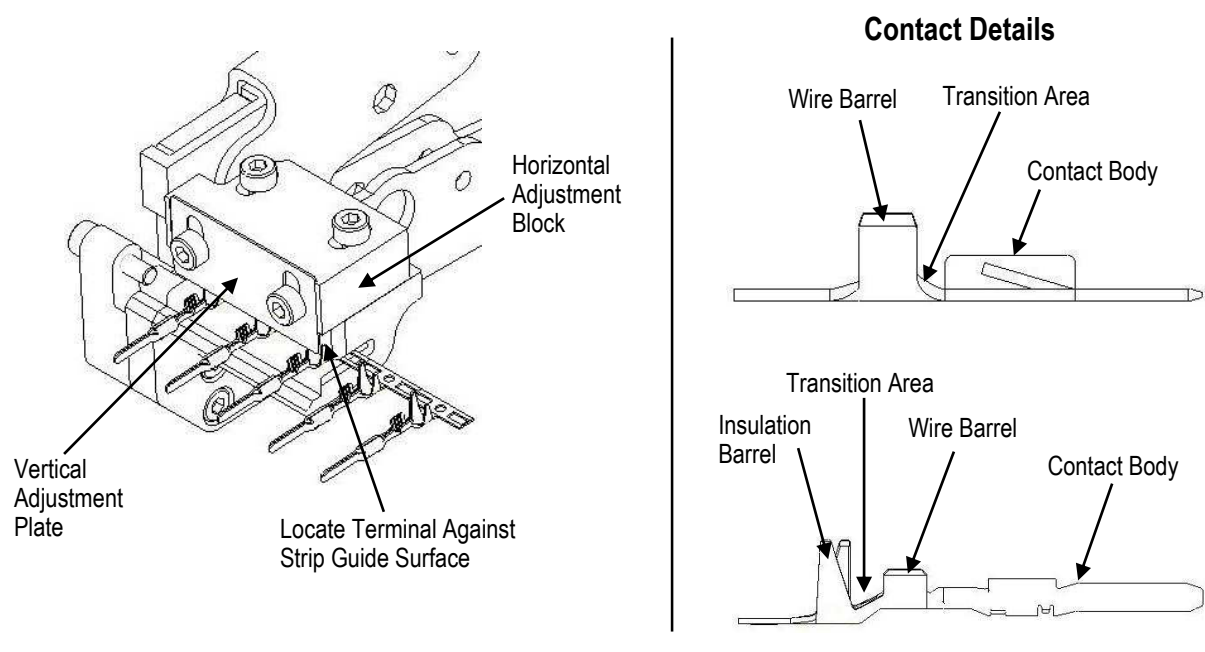

Figure 7

4. Rotate the tool in a vertical orientation.
  - a. Slide the Horizontal Adjustment Block towards the tool handles, allowing the Vertical Adjustment Plate to rest on the appropriate crimp barrel.
  - b. Position the Vertical Adjustment Plate in the transition area of the terminal, allowing clearance between the Vertical Adjustment Plate and the transition area to prevent the terminal from binding in the tool.
  - c. Tighten the Vertical Adjustment Screws.
  - d. With the Vertical Adjustment Plate resting on the appropriate crimp barrel, tighten the Horizontal Adjustment Screws.



**CAUTION**

*Do not over-tighten any of the adjustment screws, as damage to the tool may occur.*

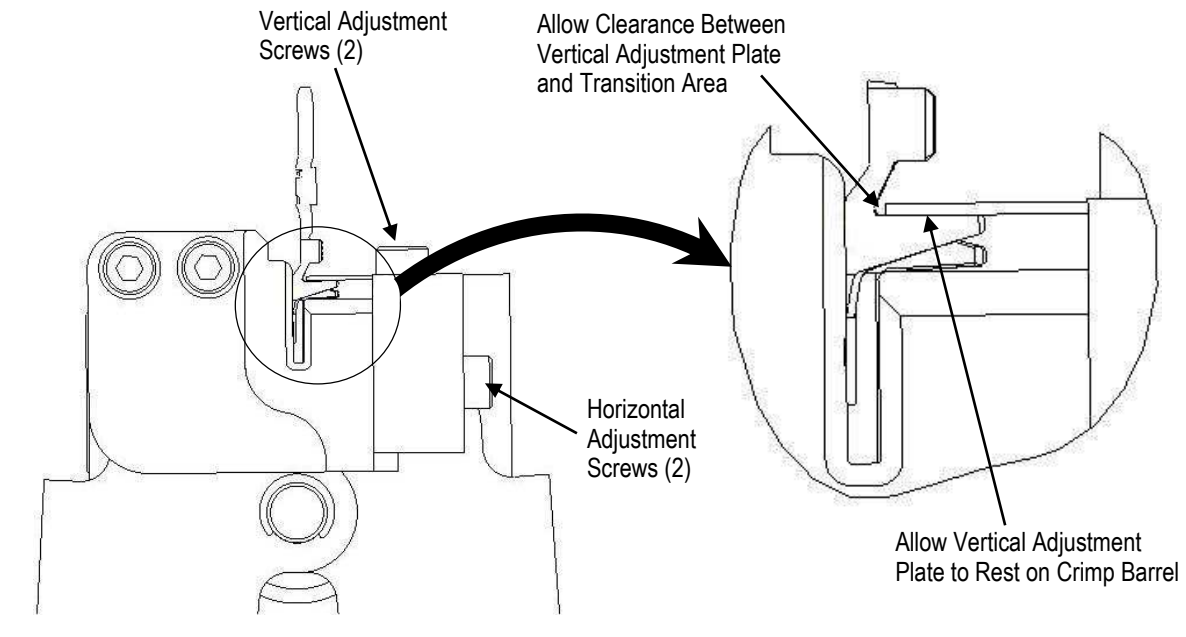

Figure 8

5. Test the adjustments by sliding the terminal strip left and right. If the terminal strip is tight and does not slide easily, loosen the Horizontal Adjustment Screws and slide the Horizontal Adjustment Block towards the contact body to allow more clearance between the contact barrels and Strip Guide.



**CAUTION**

*The terminal strip should have minimal clearance between the Insulation or Wire Barrel and the Strip Guide. Excessive clearance may allow tab length to exceed the TE requirement for the specific terminal being cut.*

6. Slide the terminal strip into the tool until the terminal contacts the Terminal Stop.  
Adjust the Terminal Stop to position the tab in the center of the Cut-off Shear (see Figure 9)

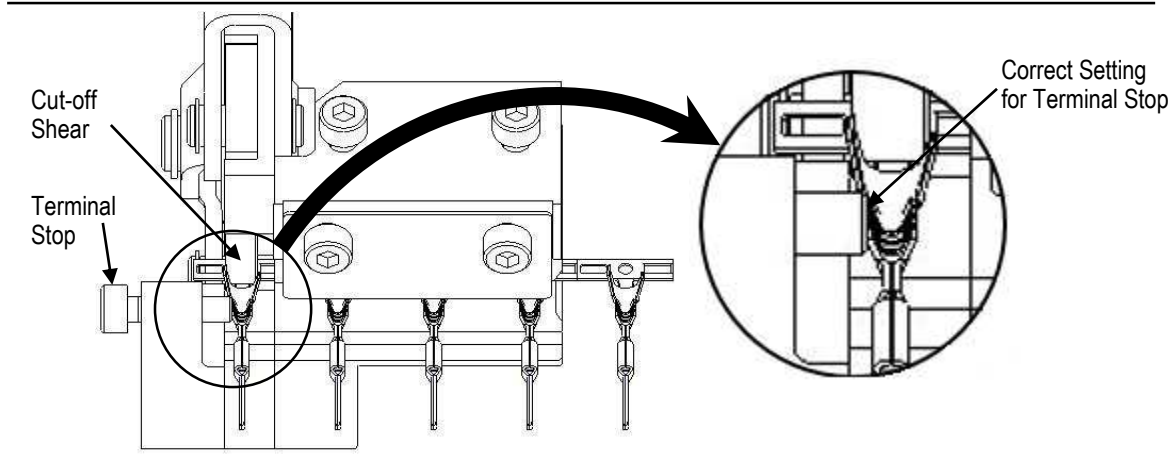

Figure 9

## 5. CUTTING PROCEDURE

1. Insert strip terminals into the Strip Guide until the Terminal Stop is reached.
2. Cycle the hand tool to shear the terminal from the carrier strip.  
Measure the cut-off tab length to confirm it is within TE specification for the specific terminal being cut. **Note:** If cut-off tab does not meet the TE specification, repeat set-up procedure in Section 4.
3. When cut-off tab length meets the TE requirement, advance terminal strip to position the next terminal against Terminal Stop and cycle tool. Additional loose-piecing of terminals may commence.

## 6. TOOL MAINTENANCE AND INSPECTION

### 6.1. Maintenance

Remove any debris with a clean, soft brush. Ensure that the tool is clean by wiping it with a clean, soft cloth. DO NOT clean with objects that could damage any components.

### 6.2. Visual Inspection

1. Inspect the tool on a regular basis to ensure excessive wear or any damage does not exist.  
If damage or abnormal wear is evident, the tool must be replaced (refer to Section 7).
2. Inspect the Cut-off Anvil and Cut-off Shear for chipped, worn, or broken areas – if evident, refer to Section 7.

## 7. REPLACEMENT

If the Cut-off Anvil and/or Cut-off Shear are damaged or worn excessively, the tool must be replaced. Order a new tool through your TE representative; call 1-800-522-6752, send a facsimile of your purchase order to 717-986-7605, or write to:

CUSTOMER SERVICE (038-035)  
TE CONNECTIVITY CORPORATION  
PO BOX 3608  
HARRISBURG PA 17105-3608

## 8. REVISION SUMMARY

Initial Release