

THIS DRAWING IS UNPUBLISHED. RELEASED FOR PUBLICATION
 © COPYRIGHT BY TYCO ELECTRONICS CORPORATION. ALL INTERNATIONAL RIGHTS RESERVED.

LOC		DIST		REVISIONS			
P	LTR	DESCRIPTION	DATE	DWN	APVD		
	R	REV PER ECO-10-000179	27JAN10	PY	RL		

1. THIS PART CONFORMS TO REQUIREMENTS FOR DANIELS CRIMP TOOL NO. M300-BT, WITH DANIELS POSITIONER PART NO. SP689, STRIP LENGTH .375, #8 AWG SETTING 7, #10 AWG SETTING 3.
2. MATES WITH 211161-1 IN AMPLIMITE CONNECTOR ASSEMBLIES ONLY.
3. FINISH: PLATED GOLD .000050 [0.00127] MIN THK PER MIL-G-45204 OVER NICKEL .000050 [0.00127] MIN THK PER QQ-N-290.
4. FINISH: PLATED GOLD .000030 [0.00076] MIN THK PER MIL-G-45204 OVER NICKEL .000050 [0.00127] MIN THK PER QQ-N-290.
5. NOT FOR GENERAL DISTRIBUTION; USAGE RESTRICTED TO SPECIFIC CUSTOMER CONFIGURATION.

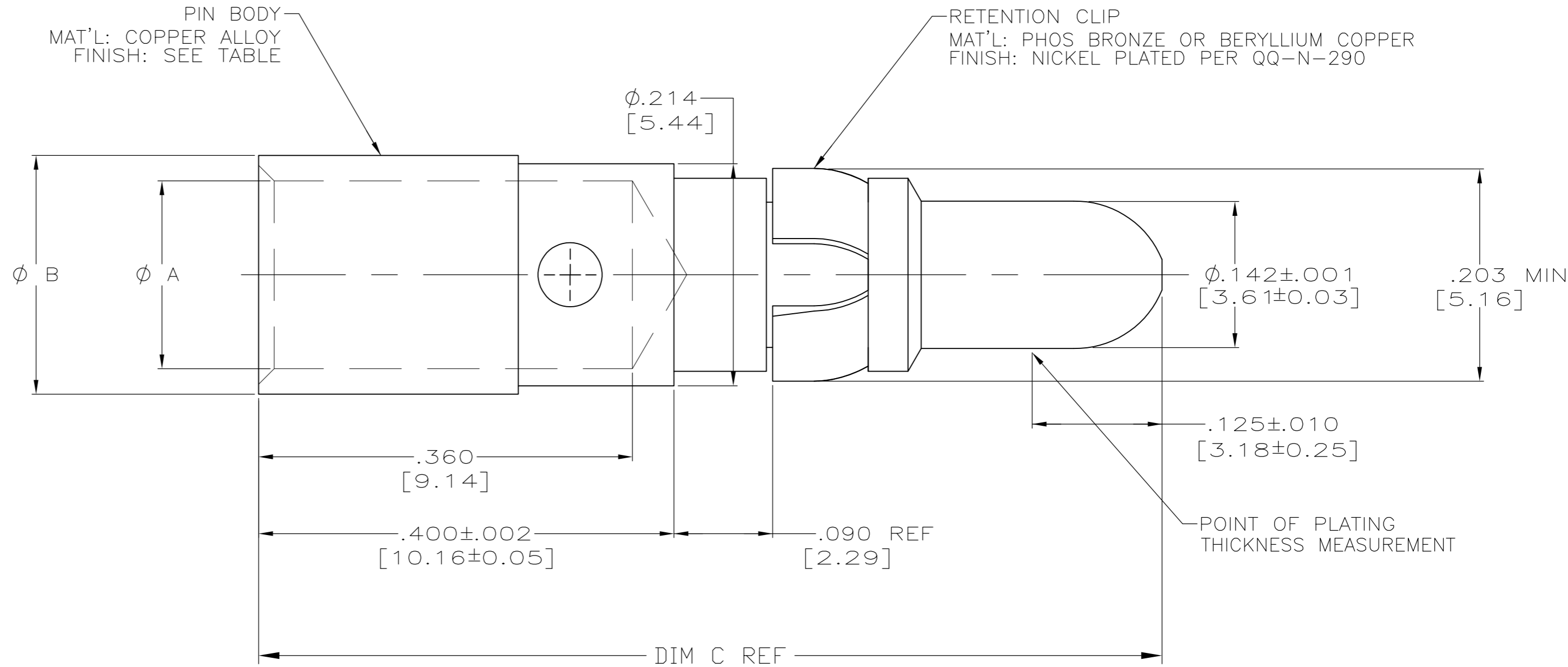

PRELIMINARY- NOT RELEASED FOR PRODUCTION	5	3	.948 [24.08]	.230 [5.84]	.181 [4.60]	#8 AWG	211159-5
PRELIMINARY- NOT RELEASED FOR PRODUCTION	2	4	.870 [22.10]	.185 [4.70]	.136 [3.45]	#10 AWG	211159-4
PRELIMINARY- NOT RELEASED FOR PRODUCTION	2	4	.870 [22.10]	.230 [5.84]	.181 [4.60]	#8 AWG	211159-3
	2	3	.870 [22.10]	.185 [4.70]	.136 [3.45]	#10 AWG	211159-2
	2	3	.870 [22.10]	.230 [5.84]	.181 [4.60]	#8 AWG	211159-1
REMARKS	FINISH	DIM C	DIM B	DIM A	WIRE SIZE	PART NUMBER	

THIS DRAWING IS A CONTROLLED DOCUMENT.

DWN	C.C.THOMAS	11/10/00	Tyco Electronics Corporation Harrisburg, PA 17105-3608
CHK	D.MILLER	11/10/00	
APVD	D.MILLER	11/10/00	
PRODUCT SPEC	108-10045		
APPLICATION SPEC	114-10014		NAME
MATERIAL	SEE CALLOUTS	FINISH	SEE TABLE
WEIGHT	-	SCALE	10:1
CUSTOMER DRAWING		SHEET	1 of 1

ASSEMBLY, PIN CONTACT
POWER VIII, #8 & #10 AWG

SIZE: A2 CAGE CODE: 00779 C=211159 RESTRICTED TO: -

SCALE: 10:1 SHEET: 1 of 1 REV: R